

# Smart Alarm System

---

**USER MANUAL**

---



# Table of Contents

<b>Preface</b> .....	1
<b>Main Features</b> .....	1
<b>Technical Information</b> .....	2
<b>Front Panel View</b> .....	3
<b>Daily Operation</b> .....	6
Contacts.....	6
Adding/Removing Contact/SMS Phone Numbers.....	6
System settings.....	7
Date & Time Setting.....	7
Password Setting.....	7
Volume Setting.....	8
Doorbell Setting.....	8
Display Setting.....	9
language Setting.....	9
Restore Factory Setting.....	9
Record Settings.....	10
Recording Your Own Message.....	10
Alarm Settings.....	11
Delays - Entry & Exit Delay.....	11
Scheduling Arm / Disarms.....	12
Siren Setting.....	13
Siren Time.....	13
Wireless Sirens.....	14
Power / Battery Notices.....	15
Working with Accessories.....	16
Remote Control.....	16
Wireless Sensors / Detectors.....	16
Arming and Disarming Introduction.....	19
Controlling the System over the Phone.....	20
Smart Outlets.....	21

WIFI Setting.....	24
Download the App.....	24
Register account.....	24
Bind the device.....	24
Settings in APP Introduction.....	28
Edit Device name/Device location/Share Device/Remove Device.....	29
Zone Setting.....	30
Modify Zone Name.....	30
Setting Zone Type/Device Type.....	30
Add/Delete Accessories via app.....	31
Installation of the Detectors.....	32
<b>Maintenance.....</b>	<b>33</b>



---

# 1. Preface

Thanks for choosing our WIFI + GSM home alarm system. This system has implanted the most advanced and popular WiFi technology into traditional WIFI+GSM alarm system technology, which with simple wireless set up and easy-read TFT display.

It's very convenient for users to set up the alarm system via App. Compared with traditional SMS app, all the settings can be done on mobile APP. This alarm system is widely used in family, factories, schools, shops, convenience stores, villas, residential areas where needs to protect.

Caution: To ensure that you can enjoy the impeccable warranty service, please do not open the panel housing to repair. Otherwise we will not provide free warranty service. All the losses and adverse consequences will be assumed by users.

---

## 2. Main Features

- WIFI+ GSM home alarm system with TFT display.
- Support 99 wireless zones + 4 wired zones.
- Support 99 wireless sensors, 20 remote controls and 4 wired sensors.
- Support 9 groups alarm phone call No.+ 9 groups SMS phone No.
- Android + IOS APP application easy to control.
- Low-battery detection/Power off detection.
- Voice prompt for all the operations.
- Support all smart life product Linkage control.
- Wireless learning code, fast and easy to add new accessories.
- Built-in siren: 100dB (Alarm loudness).
- Support 20 second recording function.
- Built-in transmitter, can connect with wireless outdoor siren.
- Support multi language menu, voice operation notice:  
English/Russian/French/Spanish/Vietnamese/Italian/Polish/Dutch/Turkish...etc

### 3. Technical Information

---

- Input Voltage: 5V/1A
- Static Current: <25mA
- Alarm Current: <500mA
- Back up Battery: Lithium DC3.7V, 400mAH battery
- Standby Time: 3h
- GSM Frequency: GSM 850/900/1800/1900MHz
- WIFI Frequency: 2.4G
- Receiver and Transmitting Frequency: 433MHz, 2262/3M-4.7M, EV1527/300K

# 4. Front Panel View

## Keypad Buttons

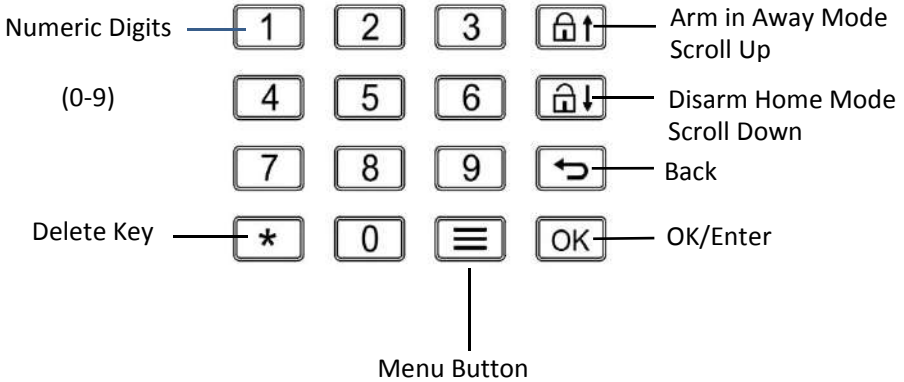

## Main Panel ( back )

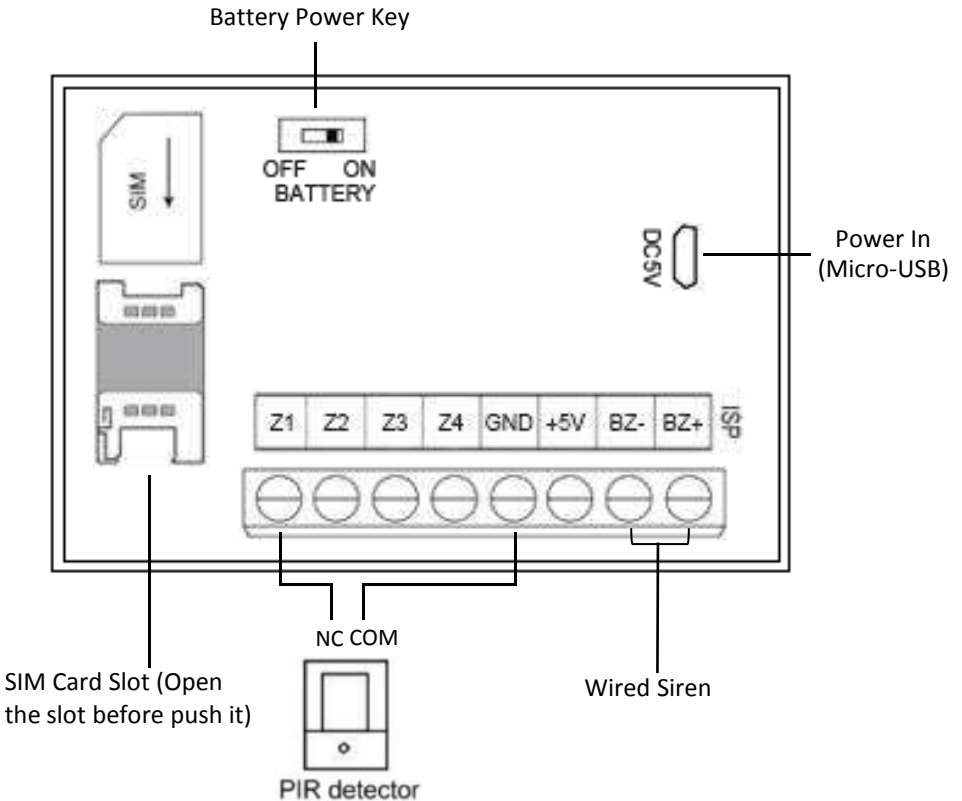

## Navigating the Menus

### ( 1 ) Waking the screen

If the device does not operate for a long time, it will go into sleep state (Around 60seconds). The device would still be powered on and working under sleep state, but the screen would be dark. To press any key on the keypad can wake the screen.



*Waking the screen*

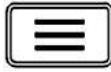

*The Menu Button*

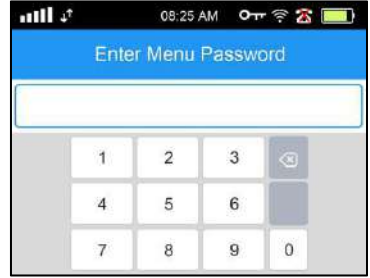

*Enter Password*

From the screen, you can press the **Menu Button** to access the Main Menu. If Menu Lock is enabled, you'll need to enter your 6-digit Administrator **Password** first.

### ( 2 ) Scrolling, Selecting, Deleting, etc.

The **Main Menu**, pictured below contains several other menus within it, general the currently selected item in the menu will be outlined, or high-lighted, in orange.



*The Main Menu*

You can scroll through the menu options using the **scroll Up** and **Scroll Down Buttons**, and select an option with the **OK Button**. You can press the **Back Button** to back up a step.





The Menu Button



Scroll Up

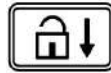

Scroll Down



Back Button



OK Button

### The Status Bar

The status Bar on the top of the screen features several icons.

Here's a break-down of what they each mean.



GSM Signal Level



Keypad Locked



Connected Server



WIFI Not Connected Router



Door Open Indicator



WIFI Connected Router



New Event(s) in Alarm Log/History



Power Cable Connected

If you see “ **NO SIM** ” instead of a GSM Signal Level, means there is no SIM card present in the panel.

If you see “  ” then a SIM card is inserted and it is currently searching for signal from a nearby cellular tower.

# 5. Daily Operation

## Contacts

### 1. Adding/Removing Contact/SMS Phone Numbers

You can specify up to 9 group phone No. and 9 group SMS No. for the system to call if the alarm is triggered. The system will call each number in order, one at a time. If no one answers, the system will call the whole list a total of 9 times.

Main Menu -> Contacts -> Alarm Call/SMS Number -> Add Contacts

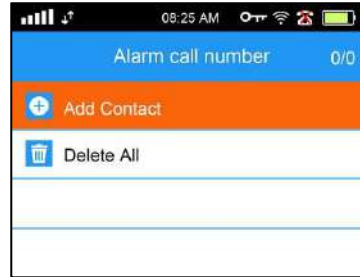

*Programming a contact phone number*

To remove a phone number or SMS No. from the list, you can select it and then select "Delete." You can also "Delete All."



*Remove one number*



*Remove all numbers*

# System settings

## 1. Date & Time Setting

You can modify the current date and time on the panel by navigating to the **System Menu**, then selecting **Date & Time**. You can also choose between 24-hour mode or 12-hour mode.

Main Menu -> System -> Date & Time

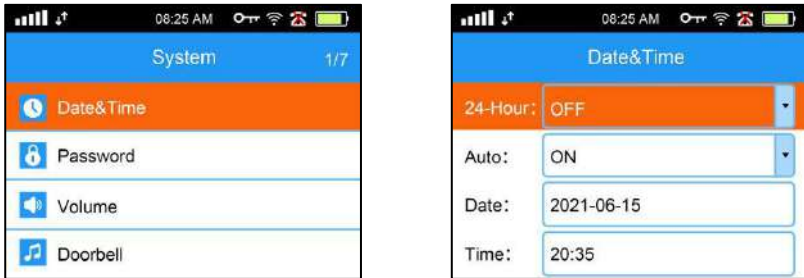

*The Date & Time Menu*

## 2. Password Setting

The device uses two passwords: the 4-digit **User Password** is used to disarm your system, and the 6-digit **Menu Password** is used to access your menus and adjust settings in the panel.

Default User Password (disarm):

**1234**

Default Administrator Password (Access menus):

**888888**

Main Menu -> System-> Password

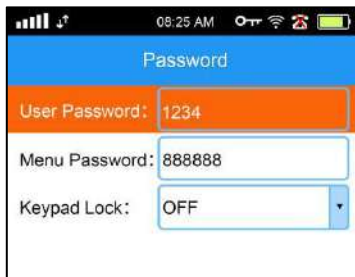

*Changing the passwords*

### 3. Volume Setting

The **Volume Menu** allows you to adjust the **Voice Volume** (the volume of the voice spoken by the panel), as well as the **Alarm Volume** (the volume of the built-in siren in the main panel). The option for voice is 1~7, OFF means silent and 7 means the loudest volume.

#### Key Tone

The device will respond with a short beep or tone when pressing buttons on the keypad of panel. This Key Tone option can be toggled on or off in this menu.

#### Mode Tone

The panel will respond with a voice when you arm/disarm panel. This Mode Tone option can be toggled on or off in this menu.

Main Menu -> System -> Volume



*The Volume Menu*

### 4. Doorbell Setting

The **Ring**: The system supports two sets of doorbell music.

The **Volume** of doorbell: The ring volume of the voice is 1~7, OFF means silent and 7 means the loudest volume.

Main Menu -> System -> Doorbell

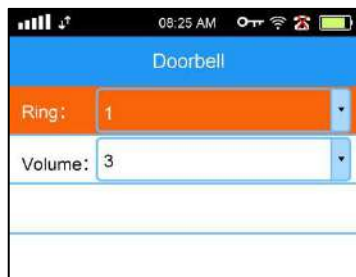

*The Doorbell Menu*

## 5. Display Setting

The **Screensaver** determines how long the timeout will be before the panel's screen goes dark to save power.

The **Brightness** allows you to adjust the screen's brightness. There are 5 brightness levels.

Main Menu -> System -> Display



*The Display Menu*

## 6. Language Setting

The main panel supports 9 languages:

English/Russian/French/Spanish/Chinese/Italian/Polish/Dutch/Turkish

Main Menu -> System -> Language



## 7. Restore Factory Setting

Some rare issues may be resolved by performing a factory reset in the main panel, then reprogramming the system and testing again.

## Main Menu -> System -> Restore Factory



*Performing a factory reset*

## Record Settings

### Recording Your Own Message

*(Active SIM card required.)*

In the Record Menu, you can record a custom message up to 20 seconds long which will play over the phone when your system calls to the contact phone numbers.

Main Menu -> Record

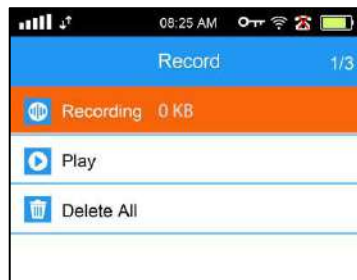

*The Record Menu*

To record a custom message, press the OK Button while Record is high-lighted. Press OK again when you're finished. Otherwise the recording stops when the 15- second countdown timer is done.

You'll also have the opportunity to listen to the message you just recorded with the Play option.

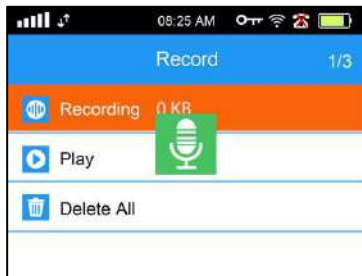

*Playing back the message*

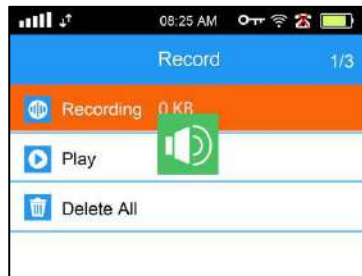

*Recording a message*

## Alarm Settings

### 1. Delays - Entry & Exit Delay

**Entry delay** can be seen as “**Alarm delay**”, **Exit delay** can be seen as “**Arm delay**”. In the Delay Menu, you can specify a system-wide Entry Delay, and a system-wide Exit Delay. These apply to all of the accessories in your system, in all Zones.

An **Entry Delay** will begin counting down if a sensor is triggered. This gives you time to walk to the main panel and disarm the system after entering your house, for example.

An **Exit Delay** will begin counting down after you arm the system in Away Armed mode. This gives you time to leave the house before the system is fully armed.

Main Menu -> Alarm-> Delay

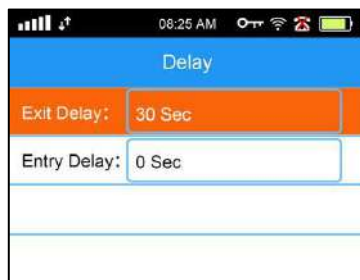

*Editing a sensor's settings*

If you don't want to set a system-wide Entry Delay for all sensors, you can set an **Entry Delay for individual sensors**, instead.

That way, only certain sensors will have a delay programmed (such as the front door), while all other sensors will still trigger the alarm immediately (such as window sensors).

Main Menu -> Sensors -> Sensors Edit



*The Delay Menu*



*The delay setting is on the second page*



*A 30-second delay has been set for this sensor.*

## 2. Scheduling Arm / Disarm

This system allows you to set the date and time in your local time zone, and then you can schedule certain events to happen automatically at certain times of day, on certain days of the week.

Once you have set the date and time on the system, you have the option of setting up a weekly schedule to make the system automatically arm or disarm itself on certain days, and at certain times of day. You can create one or more events in the list, as shown.



## Main Menu -> Alarm -> Auto Arm/Disarm



*At this scheduled day / time, the system can arm in either mode, or disarm itself.*

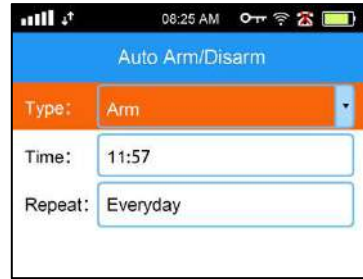

*The Auto Arm Menu with a schedule created.*

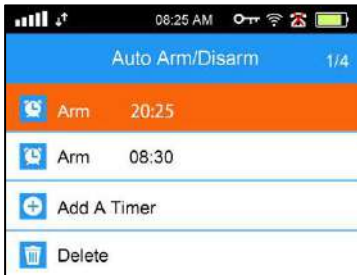

*The Auto Arm Menu  
No scheduled events exist yet*

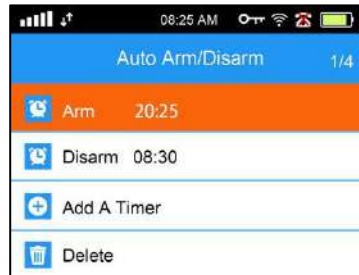

*Creating a scheduled event  
in the Auto Arm Menu.*

### 3. Siren Setting

#### 3.1 Siren Time

This menu has a few different options that we can specify.

The **Siren Time** setting allows you to specify how long the internal and wired siren will sound for before turning itself off.

The **Wired Siren** setting allows, the wired siren will be turned ON when the alarm is sent.

The **Wireless Siren** setting allows , the wireless siren will be turned ON when the alarm is sent.

The **Panel SOS Siren** deter-mines whether the sirens will sound when the alarm is triggered, or if it will be a silent alarm.

The **Alarm Volume** setting allows, the internal siren volume. The ring volume of the voice is 1~7. (default is 7)

Main Menu -> Alarm -> Sirens



*The Siren Menu*

### 3.2 Wireless Sirens

The Alarm system works with one or more wireless sirens that can be placed anywhere within range of the panel (80 meters).

#### Programming a Wireless Siren to the Main Panel

Main Menu -> Alarm-> Sirens

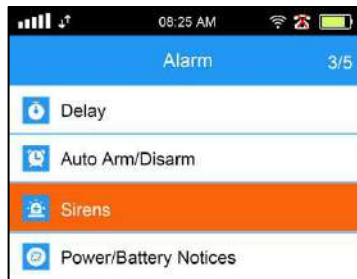

*The Wireless Sirens Menu is under the Sensors Menu.*



Once the siren is in programming Mode, press OK, selected ON



The siren will beep several times when it receives a signal form the Main panel

If you bought additional wireless sirens, then you can easily add them to your system by following the steps in this section.

First, plug in and/or turn on the wireless siren. Then set the siren into programming mode (please check user manual of siren to come into programming mode), then press "send code" of panel and wait 3 seconds. Once those steps are done, then unplug and turn off the siren, and wait for at least 5-10 seconds. Your siren is now programmed. You can plug in the siren anywhere within range of the main panel, and test it when you're ready by triggering the alarm to confirm.

#### 4. Power / Battery Notices

The panel can optionally alert you when batteries are getting low, or when power is lost or restored on the main panel. There are a few options for alerts available, as shown.

(SIM card required for SMS text messages or for calls.)

Main Menu -> Alarm -> Power Battery Notices



For each event, there are 4 alert options.

# Working with Accessories

## Remote Control

Coding remote controls with the panel as following:

Main Menu -> Sensors -> Remote

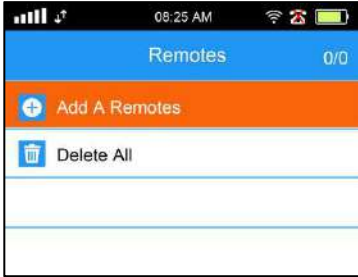

*No remotes have been added yet. Press OK to enter listening mode.*



*While the panel is listening press any key on the remote.*

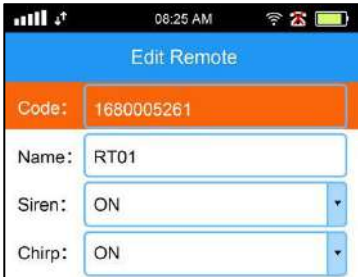

*The panel has received the signal and saved the remote.*

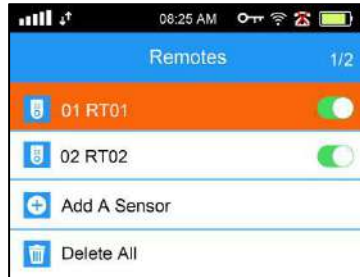

*The newly added remote now*

## Wireless Sensors / Detectors

We offers a variety of different wireless sensors and detectors that can be used with your Security System.

Main Menu -> Sensors -> Sensors

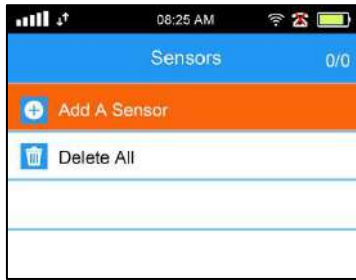

*The Sensors Menu*

## ( 1 ) Adding a Sensor



*A newly accessories are added to it. Press OK.*



*The panel is now in listening mode. Trigger the accessory. Press OK.*



*The system will automatically detect the type but you can adjust it manually.*

## ( 2 ) Settings for Sensors

Each sensor will have its own settings that can be adjusted individually.

08:25 AM

Edit Sensor 3/9

Code: 15260001

Name: Sensor 01

Type: Door Sensor

Mode: Normal

08:25 AM

Edit Sensor 8/9

Zone: 01

Siren: ON

Chirp: ON

Delay: 0 Sec

- **Name**

Assign a custom name for the sensor

- **Type**

This Type label tells the users how to respond to the alarm

- **Mode**

The mode controls how and when this sensor would trigger the alarm. (See next page)

- **Zone**

Change the Zone number where the sensor is located.

When the alarm is triggered, **the system will report the Zone number that was triggered, as well as the name of the accessory that triggered the alarm.** (For example: "Zone 01, Smoke Alarm.")

Grouping your accessories into Zones will make it easy to tell where an alarm has been triggered for systems with multiple accessories.

- **Siren**

Choose whether this sensor will cause the sirens to sound or not (silent alarm).

- **Chime** - ideal for small businesses.

If Chime is enabled and the system is disarmed, the panel will play a chime sound when this sensor is triggered.

- **Delay**

If the delay is not set to zero, then the system will wait before the alarm is triggered(Entry Delay). This gives you time to go to the main panel and disarm the system before the alarm is triggered.

### ( 3 ) Sensor Modes

There are four Modes which you can choose from for how sensors will behave.



#### • Normal

In this mode, if the alarm is **Away Armed** or **Home Armed**, then the sensor will trigger the alarm. (Entry Delay still applies.)

If the system is **Disarmed**, then the sensor will do nothing.

#### • Home - ideal for motion detectors

In this mode, if the alarm is **Away Armed**, then the sensor will trigger the alarm. (Entry Delay still applies.)

If the system is Home Armed or **Disarmed**, then the sensor will do nothing.

#### • 24H- ideal for smoke alarms, etc.

In this mode, the sensor will trigger the alarm in any state **even if the system is Disarmed**. (Entry Delay still applies.)

### Arming and Disarming Introduction

You can arm and disarm the system using a few different methods. Also, there are two different arming modes that your system can be armed in, called **Away Armed** and **Home Armed**. By default, here is how the system will behave in these different modes:

- **Away Armed** - All sensors active
- **Home Armed** - Motion detectors inactive, all other sensors active
- **Disarmed** - Only certain emergency accessories active (smoke alarm, panic button, gas leak detector, water level sensor) - all other sensors inactive.

#### • Using a Remote Control to arm or disarm (Functions of each key as following:)

- **Unlocked Padlock** (top left ) Disarm

- **Locked Padlock** (top right) Arm in Away Mode
- **House Icon** (bottom left ) Arm in Home Mode
- **SOS (bottom right) Trigger the panic alarm**

### Arm or disarm by keypad of panel:

**Disarm/Arm:** Press the **Disarm/Arm Button** (unlocked padlock).

If the Keypad Lock is enabled, you will need to enter your **4-digit User Password**.  
(continued on next page)

· **Password.** (continued on next page)

**( 2 ) Arm in Away Mode:** Press the **Arm Button** (locked padlock). If the Exit Delay is enabled, then the system will be armed when the Exit Delay is finished. You can skip the Exit Delay by pressing the **Arm Button** again.

**( 3 ) Arm in Home Mode:** After pressing the **Arm Button** once, you can press the **Arm Button** again to switch from arming in Away Mode to arming in Home Mode instead.

△Note: If the Exit Delay is enabled, you'll also need to press the **Arm Button** once to skip the Exit Delay. (see above re: Arm in Away Mode)

## Controlling the System over the Phone

In addition to using the free mobile app, you can also place a call in to the system. The system will answer your call after a certain number of rings (specified in the Siren & Ring menu), and prompt you to enter your pass-word.

After that, you can press one or more keys on your phone to control the system and access various features. You can arm and disarm the system, and even enable an intercom.

### Controlling the System over the Phone (cont.)

Here's a full list of the commands available for controlling the system over the phone.

When you place a call to the system:

Enter your password when prompted, then...

**Press 0 - Check alarm status**

**Press 1 - Enable 1-way Intercom / Listen In (SIM card required)**

**Press 2 - Turn sirens on**

**Press 3 - Turn sirens of**



---

**Press 4 - Arm the system in Away Mode**

**Press 5- Disarm the system**

**Press 6 - Enable 2-way Intercom (SIM card required)**

**Press 7 - Disable 2-way Intercom**

**Press \* - Repeat the menu options**

**Press # - Turn of the alarm, and re-arm the system**

When the system calls you:

**Press # - Prevents the system from calling any other phone numbers. This action does not disarm the system.**

**Placing an Outbound Call from the System**

*(Active SIM card required.)*

From the starting screen, you can simply begin entering numbers and a dial pad will appear. Press the **OK Button** to begin dialing.

Alternatively, you can navigate to the Phone Menu in the Main Menu, and dial from there.

You can also dial one of your programmed Contact Phone Numbers by navigating to the **Contacts Menu**, choosing the number, and the selecting **Dialing**.

## **Smart Outlets**

If you have one or more Smart Outlets with your system, these can be plugged into a regular outlet in the wall, and controlled remotely. That way, you can turn appliances on or off from anywhere. You can also define a weekly schedule for a Smart Outlet to turn on or off automatically.

### **Programming a Wireless Outlet to the Main Panel**

Any outlets that came e with your new system originally are pre-programmed by our technicians. You can plug them in and start using them right away. If you add additional outlets later, you can program them by following these steps.

First, plug in the Smart Outlet into a wall outlet for power. Initially, you'll see a red light to indicate that the Smart Outlet is turned off.

**Red light** = Smart Outlet is OFF.

**Blue light** = Smart Outlet is ON.

Next, we'll create an Outlet in the system's menu, and then sync the panel with the Smart Outlet.

Main Menu -> Sensors -> Wireless Outlets

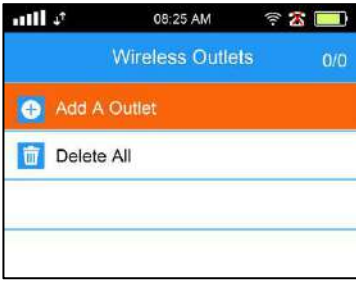

*An outlet is now ready to be synced  
To the system.Press OK*



*An outlet has now been created.  
Press Back once.*

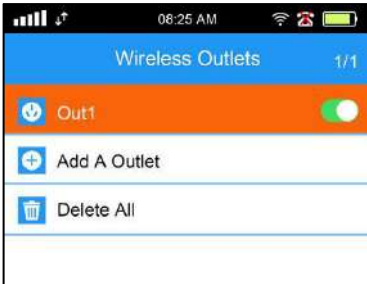

*No outlets have been added yet.  
Press OK to add outlet.*



*Select Edit,and Press OK*

At this point, **press and hold** the white button on the front of the Smart Outlet, **until the red light turns off**. Then, continue below.



*From this screen  
Press the OK button once.*



*Pressing back takes  
Us back to the outlet list.*

Now, **press the white button** on the Smart Outlet. The light on the Smart Outlet will turn red.

Your Smart Outlet is now programmed. You can test it by turning it on and off from the panel.

The Smart Outlet's light will turn blue to indicate that it's turned on. Any appliance plugged into the Smart Outlet will now be receiving power.

### Creating a Schedule for a Smart Outlet

The Smart Outlet can be programmed with a weekly schedule to turn on and off automatically at different times. Set one or more Timers to create the schedule, as shown.



*No timers have been created yet.  
Press OK to add a timer*

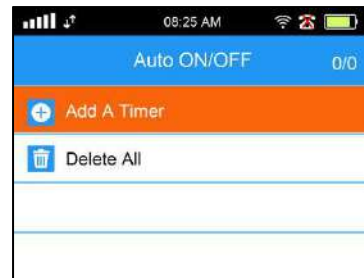

*From this screen  
Press the OK button once.*

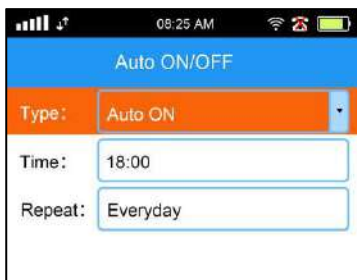

*The Timer setup screen*

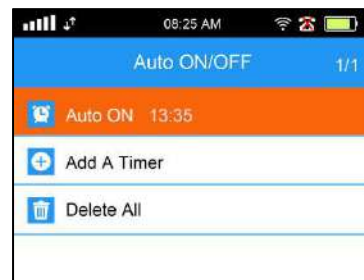

*The Timer now appears in the list.  
Scroll down to add more Timers.*

# WiFi Setting

## Download the App

You can download the free mobile app for iOS or Android by scanning the app download QR code in the System or Search "Smart Life" from App Store or Google Play.

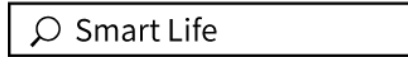

## Register account

Please register first if you don't have a Smart Life APP account, select the your **country Region** and enter your E-mail.

## Bind the device

First enter the panel into "EZ/BL" WiFi Config Mode.

Main Menu -> WiFi -> EZ/BL Mode Config



## Method 1: Bluetooth distribution network

1. Make sure the phone is connected to the 2.4G WiFi network.
2. Turn on Bluetooth of mobile phone.
3. Turn on smart life app and click “+” and choose “Add device” and click “Add--- Discovering devices” and input wifi name and password.
4. Finally the device added successfully and click “Done”

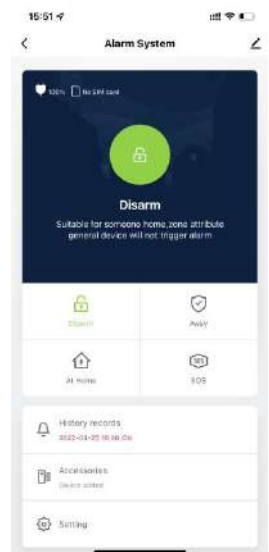
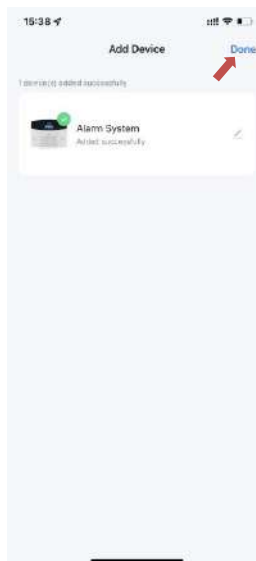
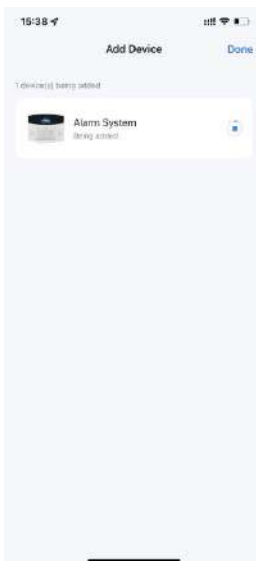
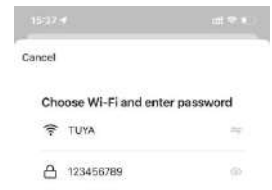
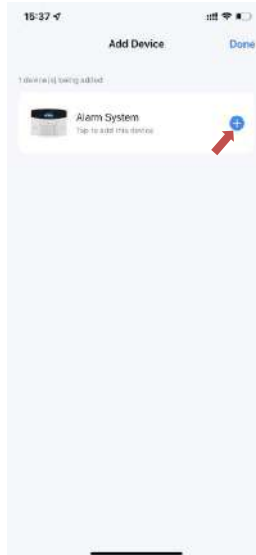

## Method 2: Wi-Fi Quick Connect Network

1. Make sure the phone is connected to the 2.4G WiFi network.
2. Open the APP, In the Home click the " + " and choose "Add device" in the upper right corner.
3. Enter the panel into **Main Menu -> WiFi -> Device QR Code**.
4. Click the "  " icon in the upper right corner to scan such QR Code.
5. Then choose "Next, Next, Next and choose Blink Quickly"
6. Finally choose "+" and click "Done"



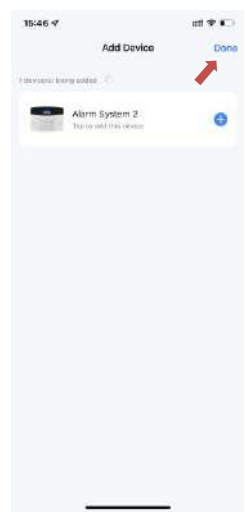

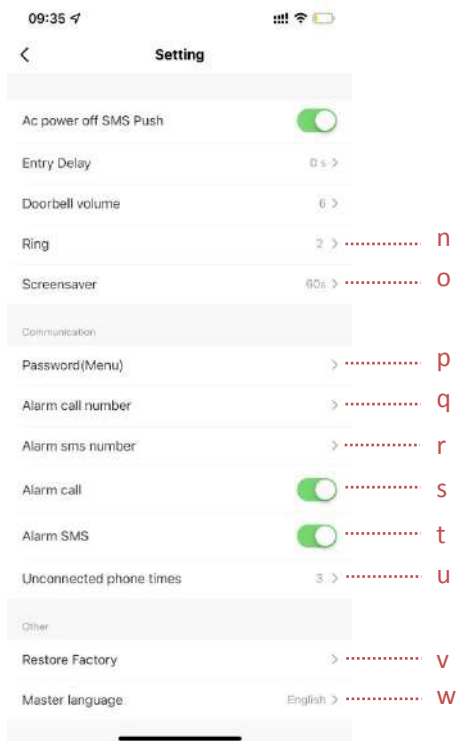
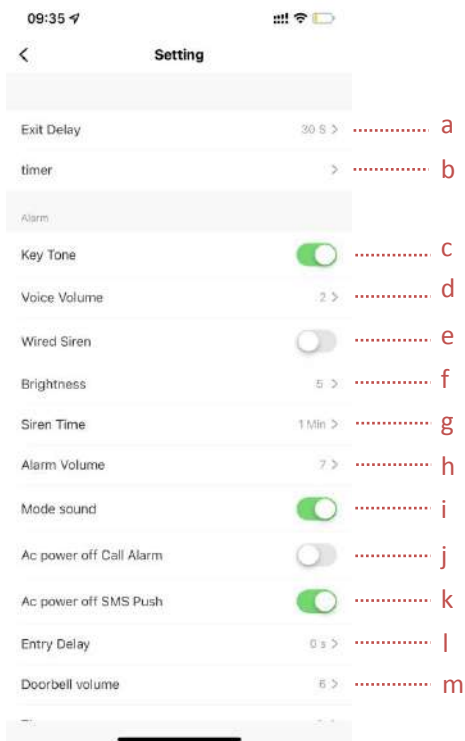

## Settings in APP Introduction

- a: **Exit delay:** Arm Delay Setting
- b: **Timer:** Arm/Disarm/Stay arm/SOS Timing Setting
- c: **Key Tone:** On/Off press key tone of device.
- d: **Voice Volume:** High/low volume of the voice spoken by device.
- e: **Wired siren:** On/off the sound of wired siren.
- f: **Brightness:** Device screen's brightness Setting.
- g: **Siren Time:** Specify how long the internal and wired siren will sound for before turning itself off.
- h: **Alarm Volume:** Internal siren volume of device.
- i: **Mode sound:** voice when you arm/disarm panel.
- j: **AC power off Call Alarm** (Should preset call phone No.)
- k: **AC power off SMS push** (Should preset SMS phone No.)
- l: **Entry Delay:** Alarm Delay Setting.
- m: **Doorbell volume:** High/low volume of doorbell function.
- n: **Ring:** Two types doorbell's voice.



o: **Screensaver**: Time of panel's screen setting.

p: **Password(menu)**: Setting Password of panel's Access menus.(Default password is 888888)

q: **Alarm call number**: totally can set 9 groups call phone No.

r: **Alarm sms number**: totally can set 9 groups sms phone No.

s: **Alarm call**: On/Off call when alarm.

t: **Alarm sms**: On/Off sms when alarm.

u: **Unconnected phone times**: Dial times of the panel if user did not get the call, default times is 1.

v: **Restore Factory**: All operations of the device will return to the factory state except accessories' operations.

w: **Master language**: User choose the language of device that wanted.

### Edit Device name/Share Device/Remove Device

Choose the Device that you want to edit and then click  , then choose "Device name" to edit. If want to edit others, same operation like this.)

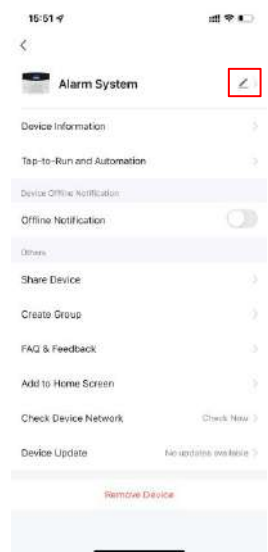
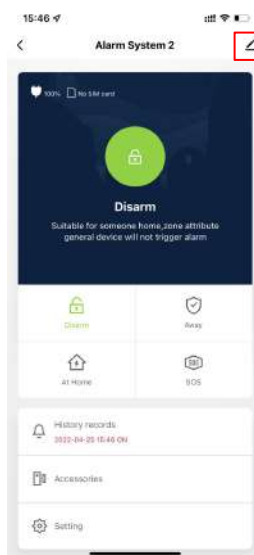
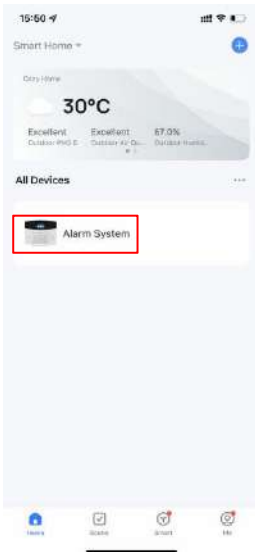

## Zone Setting:

### 1. Modify Zone Name

Steps: Click “Accessories” → Click “Detector” → Choose the detector which want to Modify → Click “Sub device name” → Enter name → Click “Save”

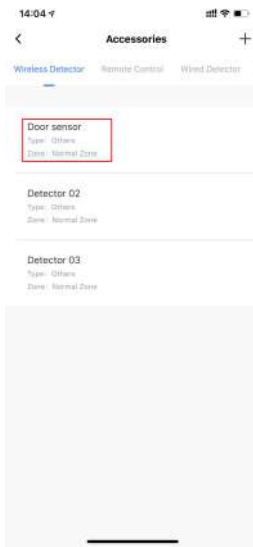

### 2. Setting Zone Type/Device Type

**Zone Type Steps:** Click “Accessories” → Click “Detector” → Click “Zone attribute” → Choose the Type you needed → Click “Save”

**Device Type Steps:** Click “Accessories” → Click “Detector” → Click “Device Type” → Choose the Type you needed → Click “Save”

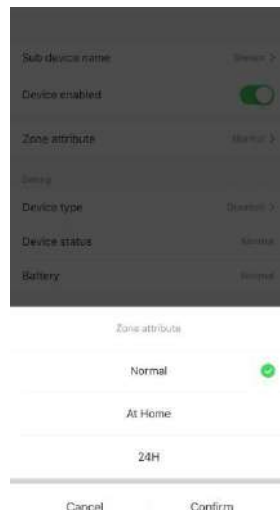
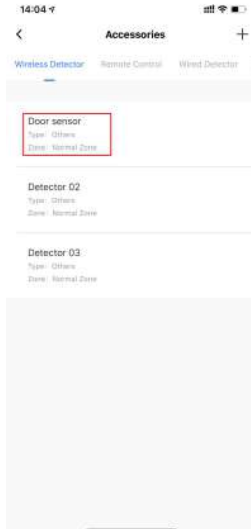

## Add/Delete Accessories via app

**Add accessories:** Click “Accessories” icon → Click “the sensors type you need to add” → Click “+” → Click “Confirm” (Sensors type including Wireless detector/Remote Control/Wired Detector....For example, you want to add “Door sensor”, then choose “Wireless detector type”. If you want to add “Remote control”, then choose “Remote control”..)

**Delete accessories:** Click “Accessories” icon → Click “the sensors type you need to delete” → Select the sensor/remote and press and hold, then swipe left to Delete

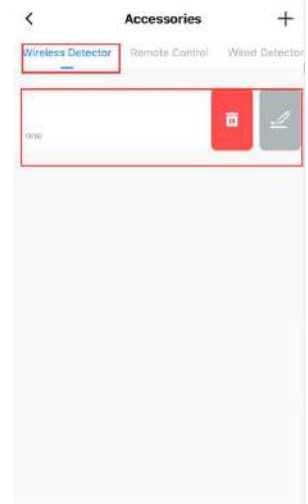
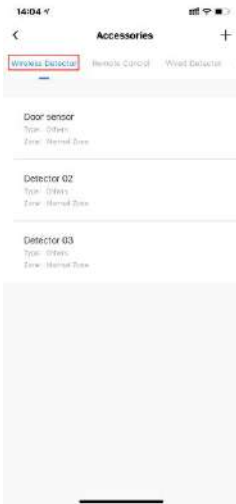

### Tips:

Users can add wireless pir/door/smoke/gas/beam/sos button/vibration /glass breaker detectors in Wireless Detectors place.

## Installation of the Detectors

The Installation Diagram of Magnetic Door Detector:

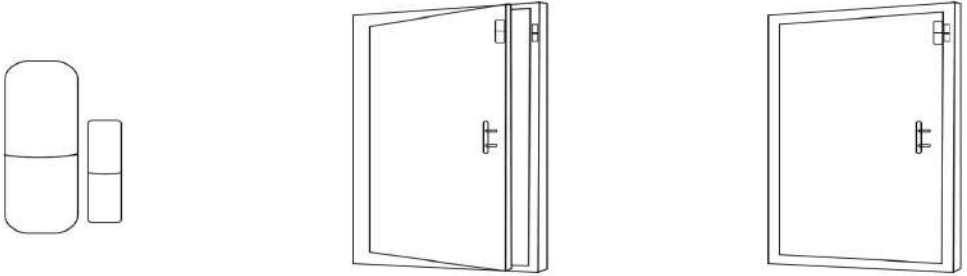

### Caution:

- A: The gap between the magnet and the sensor should be less than 10mm.
- B: After the installation, if the indicate light of the detector is on when the door is open. It proves it is installed successfully.
- C: If the indication light of the door detector flashes when it is triggered, it means the battery of the sensor is in low voltage, and you need to change the battery as soon as possible.
- D: The transmit distance of the detectors is less than 100meters in the open area, please test the distance before installing. The obstacles will change the transmitting distance.

The Installation Diagram of PIR Motion Detector:

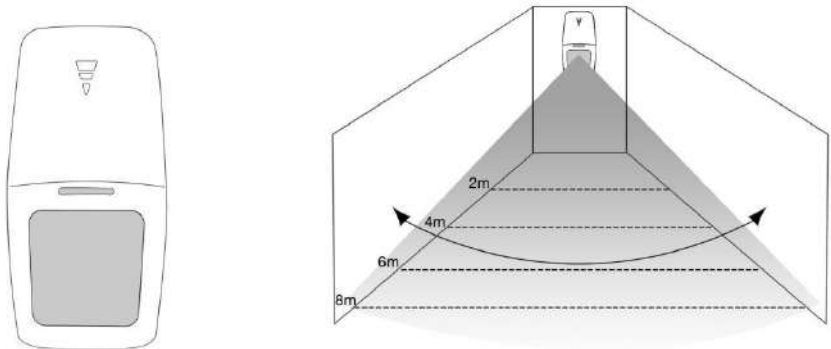

To avoid the false alarm, please pay attention to the following point in stalling the PIR motion detector;

---

A: Do not face the glass window.

B: Do not face the big object which is easy to swing.

C: Do not face the cold and heat air vent or cold and heat source.

D: The furniture, mini escape or any other isolation should be away from the detecting scope.

E: Do not install two or more detectors in the same area or it will cause the interference when alarm.

F: When the detector is triggered and the LED indicator flashes, it means the battery is in low voltage, please change it as soon as possible.

## 5.Maintenance

---

### **System Inspection:**

The System need periodic inspection to ensure the stable and safe work. We suggest the users to inspect the system per three month and inspect the detectors per month.

### **Alarm Host Inspection:**

A: Check whether the host can arm or disarm normally.

B: Check whether the host can call through the phone numbers when alarm occurs.

C: Check whether the host can receive the signal from detectors normally and back-up battery work normally or not.

### **Detector Inspection:**

A: Trigger the detector by hand to check whether it can send the alarm signal successfully or not.

B: Check the battery of each detector to see whether it is short of voltage.

### **Cautions:**

A: Do not disassemble, repair, transform the products privately, or it will cause fault or accident.

B: Do not fall the product on the hard ground to avoid the fault or damage because of the strong crash.

C: Do not set "911" or any security department's telephone numbers as the alarming phone numbers without any authorization.